

Microelectronic gauge pressure sensors HPL Series

- Resolution 0,01 %
- Operating pressure range
from 0-0,06 to 0-150 MPa
- Operating temperature range
from -45 to +200 °C
- Electrical insulation
strength – 700 V
- Titanium body

Applications

- ★ Industrial automatics
- ★ Oil and gas industry
- ★ Hydraulics/ Pneumatic
- ★ Pumping stations/ Compressors
- ★ Heat metering



- The sensors are intended for proportional conversion of pressure into electric signal.

New solutions in pressure measurement – “Silicon-on-Sapphire” Technology

- ✓ Sensitive element of pressure sensors is a two-layer sapphire-titanium membrane with monocrystal silicon resistance strain gauges.
- ✓ Monocrystal sapphire membrane is a perfect elastic element that due to connection with titanium acquires the best quality as to the deformation level, and preserves its elastic properties up to +400°C.
- ✓ Monocrystal silicon resistance strain gauges are automatically connected with sapphire (heteroepitaxy method) and provide almost no hysteresis or fatigue effects.
- ✓ Exceptional insulating properties and radiation resistance of sapphire enable to use the sensitive element within temperature range from -200 to +350°C under the effect of high electromagnetic interferences and radiation.
- ✓ Strain gauges elements are manufactured in groups by solid-state micro-electronic methods and provide high quality and good repeatability of the output parameters.

Microtensor

Pressure sensors HPL Series

Datasheet

1 Nominal, overload and burst pressure

Designation	Nominal pressure, MPa	Overload pressure, MPa	Burst pressure, MPa
HPL 0,06...	0...0,06	-0,1...0,12	0,18
HPL 0,1...	0...0,1	-0,1...0,2	0,3
HPL 0,16...	0...0,16	-0,1...0,32	0,48
HPL 0,25...	0...0,25	-0,1...0,5	0,75
HPL 0,4...	0...0,4	-0,1...0,8	1,2
HPL 0,6...	0...0,6	-0,1...1,2	1,8
HPL 1...	0...1	-0,1...2	3
HPL 1,6...	0...1,6	-0,1...3,2	4,8
HPL 2,5...	0...2,5	-0,1...5	7,5
HPL 4...	0...4	-0,1...8	12
HPL 6...	0...6	-0,1...12	18
HPL 10...	0...10	-0,1...20	30
HPL 16...	0...16	-0,1...32	48
HPL 25...	0...25	-0,1...50	75
HPL 40...	0...40	-0,1...80	120
HPL 60...	0...60	-0,1...120	180
HPL 100...	0...100	-0,1...150	250
HPL 150...	0...150	-0,1...165	300

2 Temperature ranges

2.1 Operating temperature range

2.1.1 Version 1from - 45 to + 125°C

2.1.2 Version 2from - 45 to + 155°C

2.1.3 Version 3from - 45 to + 200°C

Microtensor

Pressure sensors HPL Series

2.2 Limiting temperature range

2.2.1 Version 1	from - 60 to + 130°C
2.2.2 Version 2	from - 60 to + 160°C
2.2.3 Version 3	from - 60 to + 205°C

3 Accuracy parameters

3.1 Resolution, % FS	0,01
3.2 Non-linearity,% FS	
3.2.1 For HPL 0,06... - HPL 1,6...	±0,2
3.2.2 For HPL 2,5... - HPL 150...	±0,15
3.3 Variation, % FS	0,05
3.4 Output signal repeatability, % FS	±0,05
3.5 Long-term stability of the output signal range within 12 months, %	
3.5.1 For HPL 0,06... - HPL 1...	±0,25
3.5.2 For HPL 1,6... - HPL 150...	±0,15
3.6 Output signal error caused by the influence of overload pressure, % FS	
for zero output signal	±0,2
for output signal range	±0,05
3.7 Additional ambient temperature error, % FS/1°C	
3.7.1 For zero output signal	±0,05
3.7.2 For output signal range	
operating temperature range from -45 to +125 °C	±0,05
operating temperature range from +125 to +200 °C	-0,05±0,025
3.8 Additional vibration error of the output signal, % FS	±0,05
3.9 Zero output signal error caused by the torque effect on the sensors, % FS	±0,025

4 Electrical characteristics

4.1 Output signal at room temperature by stabilized DC voltage 10 V	
4.1.1 Zero output signal, mV	±10
4.1.2 Output signal range (FS), mV	150±50
for HPL 0,06...; HPL 0,1...; HPL 0,16...; HPL 0,25...	100±35
4.2 Strain gauge bridge resistance at room temperature, kOhm	3,40-4,85
4.3 Temperature resistance coefficient of the strain gauge bridge, K ⁻¹	(1,75±0,1)·10 ⁻³
4.4 Insulation resistance, MOhm	
at room temperature	100
at the upper ambient temperature value	20
4.5 Electrical insulation strength (AC voltage), V	700
4.6 Power supply by stabilized DC voltage, V	1-10

Microtensor

Pressure sensors HPL Series

5 Mechanical characteristics

5.1 Vibration resistance (sinusoidal vibration):

Frequency range, Hz from 10 to 5000
 Acceleration amplitude, m/s^2 500

5.2 Shock resistance (multiple mechanical shocks):

Shock acceleration peak, m/s^2 1000
 Shock pulse width, ms 2

5.3 Torque effect while installation:

Operating pressure range, MPa	Thread code	
	MFA, GFA, MK1, GK1	K, MFE, GFE, MA1, GA1, MT1, GT1
0,06-10	30-35 N·m	30-35 N·m
16-40	50-60 N·m	
60-150	80-100 N·m	

6 Operating conditions

6.1 IP level IP40

6.2 Sensor body (pressure connection) and membrane are made of titanium alloy with 87 % of titanium.

6.3 Pressure media - gases, liquids and their mixtures not aggressive to the titanium alloy (air, sea water, 5 % vitriol acid, chlorine water, chloride solutions, oils, ethyne etc)

Microtensor

Pressure sensors HPL Series

7 Overall and mounting dimensions

7.1 Version with pins

HPL 0,06(0,1; 0,16)-...-K-P

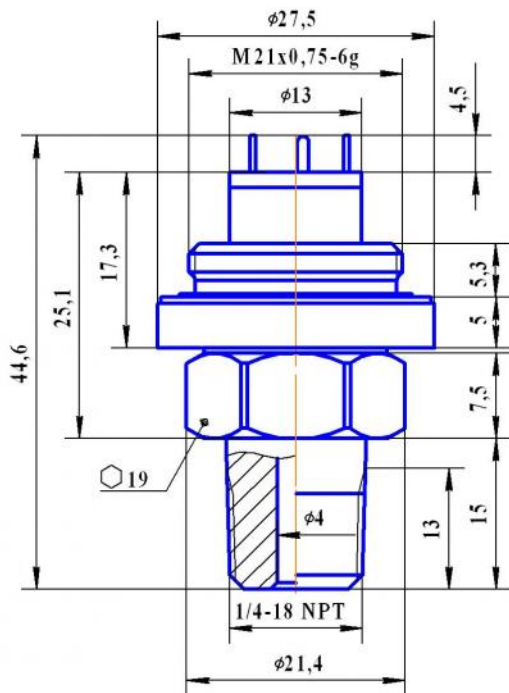

Drawing 1

Thread	Code
1/4-18 NPT	K

(in accord with
DIN 3866)

HPL 0,25(0,4...1)-...-K-P

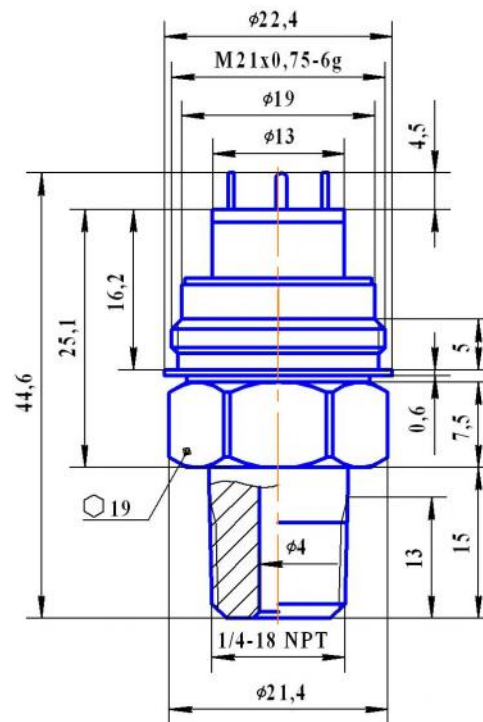

Drawing 2

HPL 1,6(2,5...100)-...-K-P

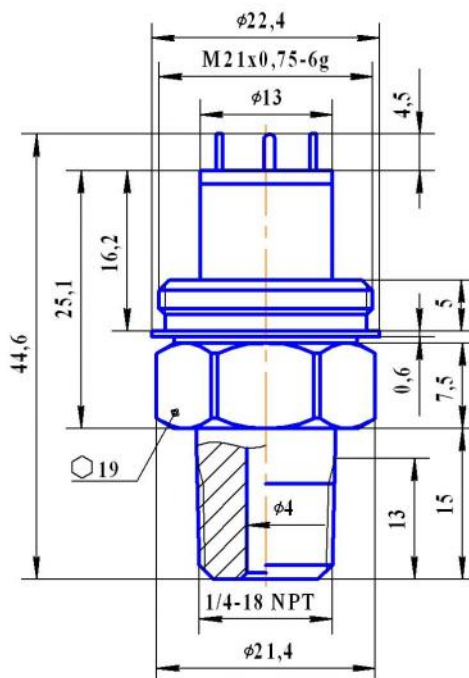

Drawing 3

Microtensor

Pressure sensors HPL Series

7.2 Version with wires

HPL 0,06(0,1; 0,16)-...-K-L

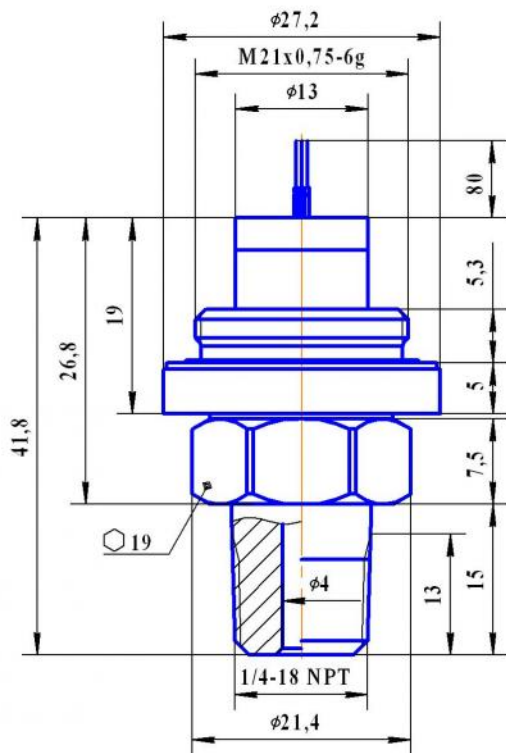

Drawing 4

Thread	Code
1/4-18 NPT	K

(in accord with
DIN 3866)

HPL 0,25(0,4...1)-...-K-L

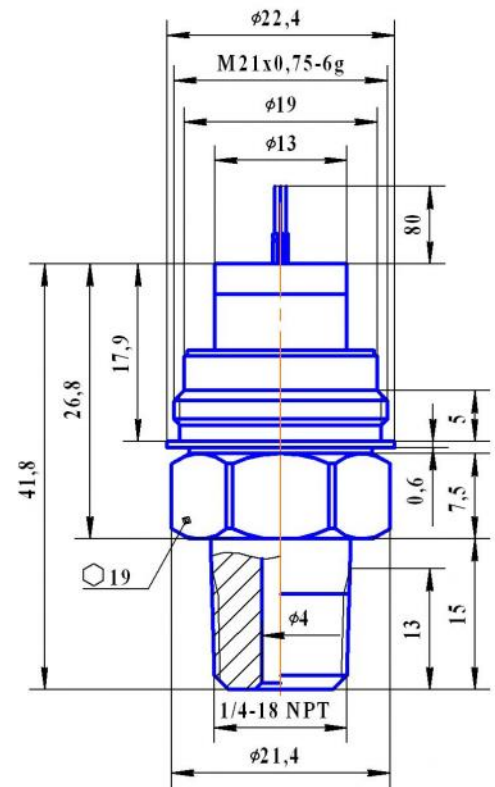

Drawing 5

HPL 1,6(2,5...100)-...-K-L

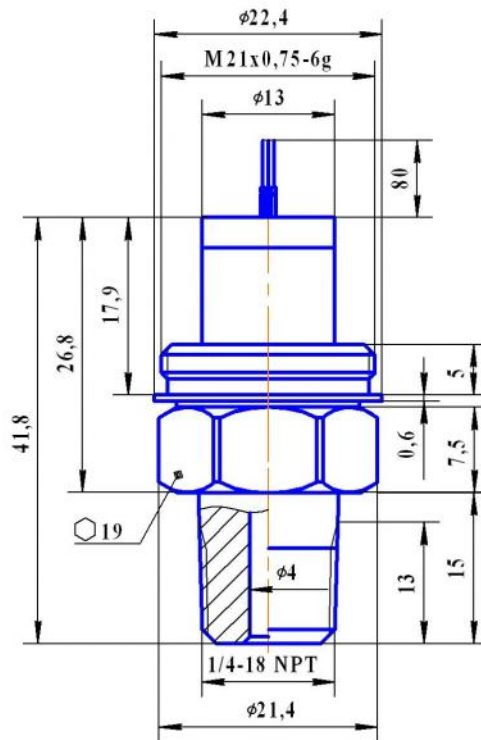

Drawing 6

Microtensor

Pressure sensors HPL Series

7.3 Thread design

HPL 0,06(0,1...100)-...-MFA(GFA)-...

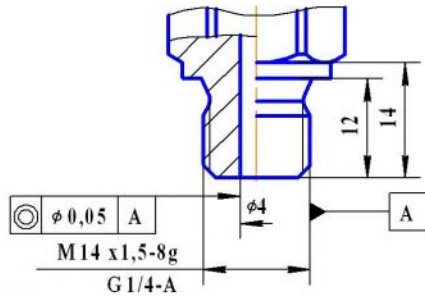

Thread	Code
M14x1,5-8g	MFA
G 1/4-A	GFA

(in accord with
DIN 3852)

HPL 0,06(0,1...100)-...-MFE(GFE)-...

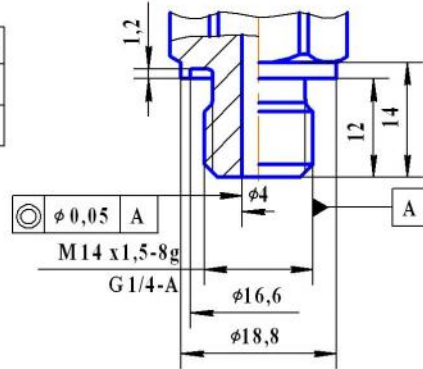

Thread	Code
M14x1,5-8g	MFE
G 1/4-A	GFE

(in accord with
DIN 3852)

HPL 0,06(0,1...100)-...-MK1(GK1)-...

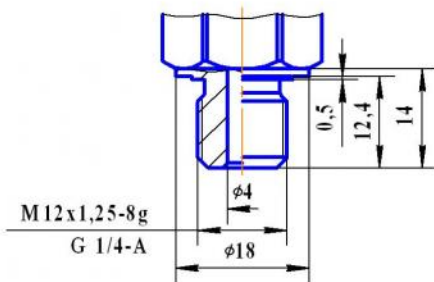

Thread	Code
M12x1,25-8g	MK1
G 1/4-A	GK1

HPL 0,06(0,1...150)-...-MA1(GA1)-...

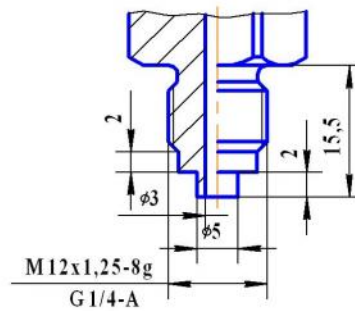

Thread	Code
M12x1,25-8g	MA1
G 1/4-A	GA1

HPL 0,06(0,1...100)-...-MT1(GT1)-...

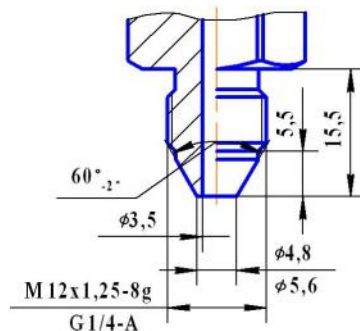

Thread	Code
M12x1,25-8g	MT1
G 1/4-A	GT1

Microtensor

Pressure sensors HPL Series

8 Circuit diagram

"Closed bridge" diagram

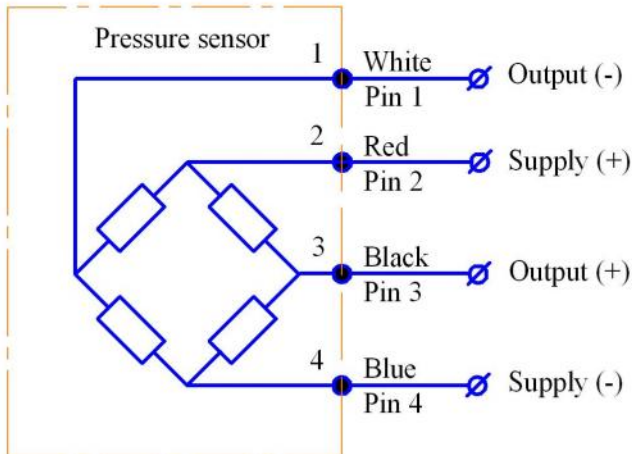

"Open bridge" diagram

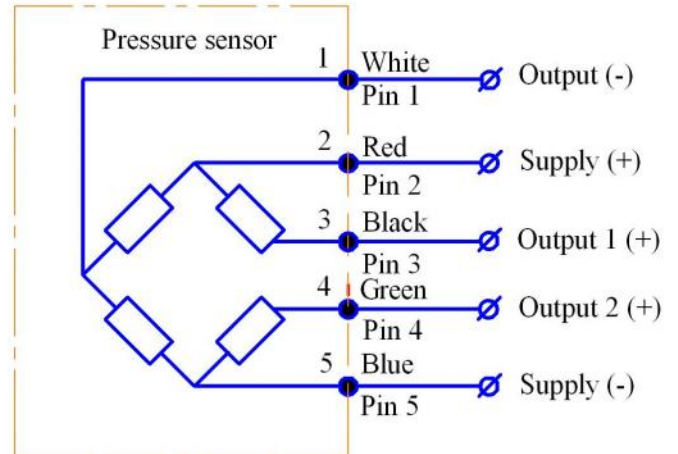

Pins configuration

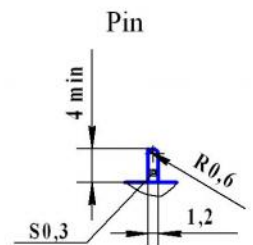
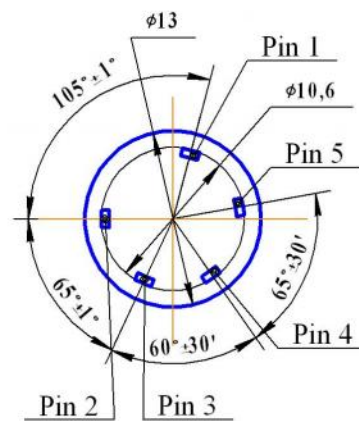
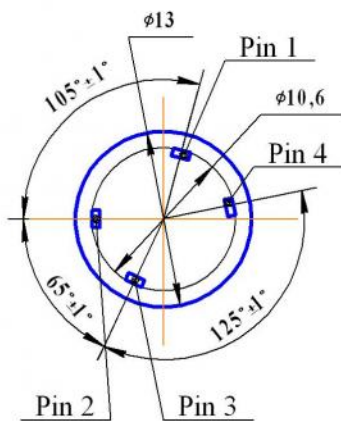

9 Mounting diagrams

HPL 0,06(0,1...100)-...-MK1(GK1)-...

HPL 0,06(0,1...150)-...-MA1(GA1)-...

HPL 0,06(0,1...100)-...-MT1(GT1)-...

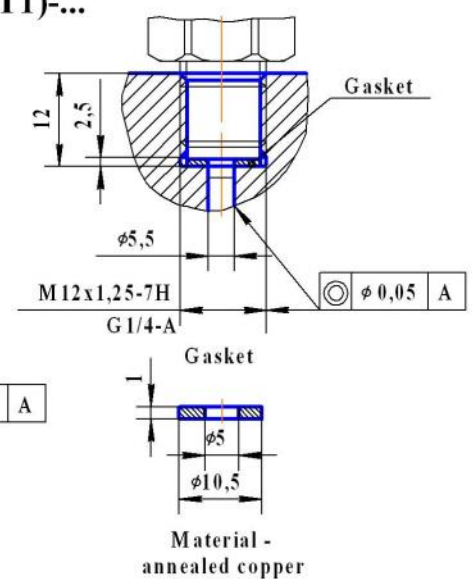
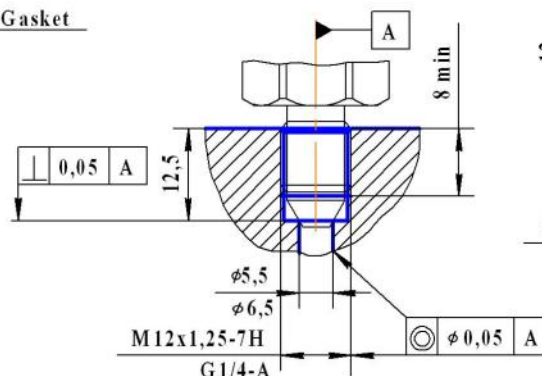
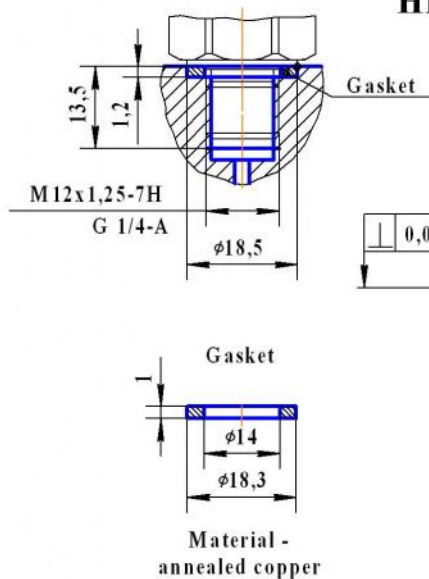

Microtensor

Pressure sensors HPL Series

10 Type designation

HPL XXX - XX - XXX - X

Series

Upper gauge pressure limit

0,06; 0,1; 0,16; 0,25; 0,4; 0,6; 1; 1,6; 2,5;
4; 6; 10; 16; 25; 40; 60; 100; 150 MPa

Operating ambient temperature range

Version 1 - from - 45 to + 125 °C;
Version 2 - from - 45 to + 155 °C;
Version 3 - from - 45 to + 200 °C

Circuit

0 - "closed bridge" circuit; 1 - "open bridge" circuit

Thread code

K - 1/4-18 NPT;
MFA - M14x1,5-8g, form A;
GFA - G1/4-A, form A;
MFE - M14x1,5-8g, form E;
GFE - G1/4-A, form E;
MK1 - M12x1,25-8g;
GK1 - G1/4-A;
MA1 - M12x1,25-8g, end seal;
GA1 - G1/4-A, end seal;
MT1 - M12x1,25-8g, cone seal;
GT1 - G1/4-A, cone seal

Electrical connection

L - flexible wire 80 mm length; P - pin 4,5 mm height

Order example of pressure sensor

Pressure sensor of HPL series, intended for pressure conversion from 0 to 60 MPa, for operation within temperature range from - 45 to + 155 °C, with "closed bridge" circuit, G1/4-A thread, cone seal and flexible wire 80 mm length:

Pressure sensor HPL 60-20-GT1-L.

Note: if wished, the wire length (standard 80 mm) can be changed, in this case the required length should be added to the wire code L, for example:

Pressure sensor HPL 60-20-GT1-L200.

11 Marking

Marking on the sensor body must contain following information: series, upper gauge pressure limit in MPa, version of the operating temperature range, circuit type, thread code and order number



Microtensor

Pressure sensors HPL Series