

Microelectronic gauge pressure sensors HP-P Series

- **Resolution** 0,01 %
- **Operating pressure range**
from 0-0,06 to 0-150 MPa
- **Operating temperature range**
from -45 to +200 °C
- **Electrical insulation**
strength – 700 V
- **Titanium body**

Applications

- ★ **Industrial automatics**
- ★ **Oil and gas industry**
- ★ **Hydraulics/ Pneumatic**
- ★ **Pumping stations/ Compressors**
- ★ **Heat metering**



- **The sensors are intended for proportional conversion of pressure into electric signal.**

New solutions in pressure measurement – “Silicon-on-Sapphire” Technology

- ✓ Sensitive element of pressure sensors is a two-layer sapphire-titanium membrane with monocrystal silicon resistance strain gauges.
- ✓ Monocrystal sapphire membrane is a perfect elastic element that due to connection with titanium acquires the best quality as to the deformation level, and preserves its elastic properties up to +400°C.
- ✓ Monocrystal silicon resistance strain gauges are automatically connected with sapphire (heteroepitaxy method) and provide almost no hysteresis or fatigue effects.
- ✓ Exceptional insulating properties and radiation resistance of sapphire enable to use the sensitive element within temperature range from -200 to +350°C under the effect of high electromagnetic interferences and radiation.
- ✓ Strain gauges elements are manufactured in groups by solid-state micro-electronic methods and provide high quality and good repeatability of the output parameters.

Microtensor

Pressure sensors HP-P Series

Lomonosov str.6, building 2, 302040 Orel, Russia
Tel/fax: +7(4862) 44-17-15, e-mail: mail@microtensor.ru

M-035
2018

Page 1

Pages 7

Datasheet

1 Nominal, overload and burst pressure

Designation	Nominal pressure, MPa	Overload pressure, MPa	Burst pressure, MPa
HP-P 0,06...	0...0,06	-0,1...0,12	0,18
HP-P 0,1...	0...0,1	-0,1...0,2	0,3
HP-P 0,16...	0...0,16	-0,1...0,32	0,48
HP-P 0,25...	0...0,25	-0,1...0,5	0,75
HP-P 0,4...	0...0,4	-0,1...0,8	1,2
HP-P 0,6...	0...0,6	-0,1...1,2	1,8
HP-P 1...	0...1	-0,1...2	3
HP-P 1,6...	0...1,6	-0,1...3,2	4,8
HP-P 2,5...	0...2,5	-0,1...5	7,5
HP-P 4...	0...4	-0,1...8	12
HP-P 6...	0...6	-0,1...12	18
HP-P 10...	0...10	-0,1...20	30
HP-P 16...	0...16	-0,1...32	48
HP-P 25...	0...25	-0,1...50	75
HP-P 40...	0...40	-0,1...80	120
HP-P 60...	0...60	-0,1...120	180
HP-P 100...	0...100	-0,1...150	250
HP-P 150...	0...150	-0,1...165	300

2 Temperature ranges

2.1 Operating temperature range

2.1.1 Version 1from - 45 to + 125°C

2.1.2 Version 3from 0 to + 200°C

Microtensor

Pressure sensors HP-P Series

2.2 Limiting temperature range

2.2.1 Version 1from - 60 to + 130°C

2.2.2 Version 3 from 0 to + 205°C

3 Accuracy parameters

3.1 Resolution, % FS 0,01

3.2 Non-linearity, % FS

3.2.1 For HP-P 0,06... - HP-P 1,6... ±0,2

3.2.2 For HP-P 2,5... - HP-P 150... ±0,15

3.3 Variation, % FS 0,05

3.4 Output signal repeatability, % FS ±0,05

3.5 Long-term stability of the output signal range within 12 months, %

3.5.1 For HP-P 0,06... - HP-P 1... ±0,25

3.5.2 For HP-P 1,6... - HP-P 150... ±0,15

3.6 Output signal error caused by the influence of overload pressure, % FS

for zero output signal ±0,2

for output signal range ±0,05

3.7 Additional ambient temperature error, % FS/1°C

3.7.1 For zero output signal

3.7.1.1 V type ±0,05

3.7.1.2 C type 0,03±0,05

3.7.2 For output signal range

operating temperature range from -45 to +125 °C ±0,05

operating temperature range from +125 to +200 °C -0,05±0,025

3.8 Additional vibration error of the output signal, % FS ±0,05

3.9 Zero output signal error caused by the torque effect on the sensors, % FS

3.9.1 For HP-P 0,25... - HP-P 1... ±0,25

3.9.2 For HP-P 0,06... - HP-P 0,16...; HP-P 1,6... - HP-P 150... ±0,025

4 Electrical characteristics

4.1 Output signal at room temperature, mV

4.1.1 Zero output signal ±10

4.1.2 Output signal range (FS) 150±50

for HP-P 0,06 100±35

4.2 Strain gauge bridge resistance at room temperature, kOhm 3,40-4,85

4.3 Temperature resistance coefficient of the strain gauge bridge, K⁻¹

4.3.1 V type (1,75±0,1)·10⁻³

4.3.2 C type (1,2±0,2)·10⁻³

Microtensor

Pressure sensors HP-P Series

4.4 Insulation resistance, MOhm	
at room temperature	100
at the upper ambient temperature value	20
4.5 Electrical insulation strength (AC voltage), V	700
4.6 Power supply	
4.6.1 V type - stabilized DC voltage, V	1-10
4.6.2 C type - stabilized DC, mA	0,2-2
Output signal is rated by the voltage 10 V and by the current 1,5 mA.	

5 Mechanical characteristics

5.1 Vibration resistance (sinusoidal vibration):	
Frequency range, Hz	from 10 to 5000
Acceleration amplitude, m/s^2	500
5.2 Shock resistance (multiple mechanical shocks):	
Shock acceleration peak, m/s^2	1000
Shock pulse width, ms	2
5.3 Torque effect while installation:	

Operating pressure range, MPa	Thread code	
	M, G	K, MA, GA
0,06-10	30-35 N·m	30-35 N·m
16-40	50-60 N·m	
60-150	80-100 N·m	

6 Operating conditions

6.1 IP level	IP54
6.2 Sensor body (pressure connection) and membrane are made of titanium alloy with 87 % of titanium.	
6.3 Pressure media - gases, liquids and their mixtures not aggressive to the titanium alloy (air, sea water, 5 % vitriol acid , chlorine water, chloride solutions, oils, ethyne etc)	

Microtensor

Pressure sensors HP-P Series

7 Overall and mounting dimensions

HP-P 0,06(0,1; 0,16)-...-K

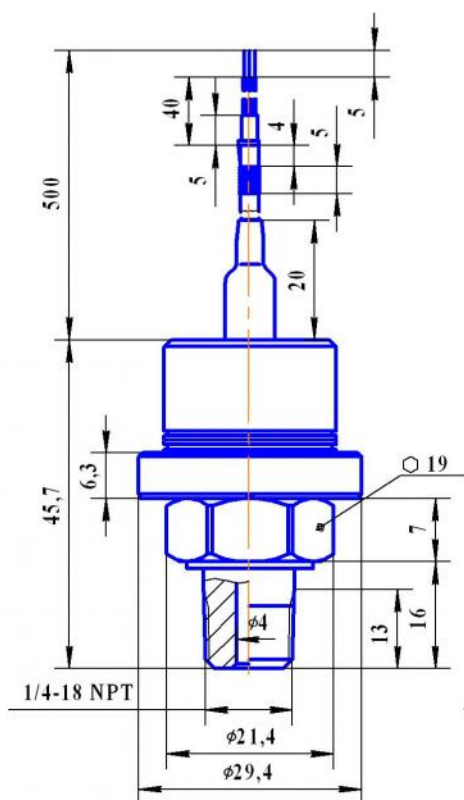

Drawing 1

HP-P 0,25(0,4...1)-...-K

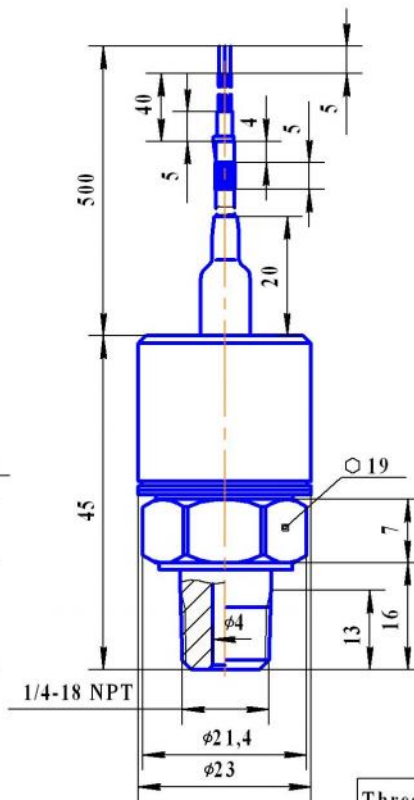

Drawing 2

HP-P 1,6(2,5...100)-...-K

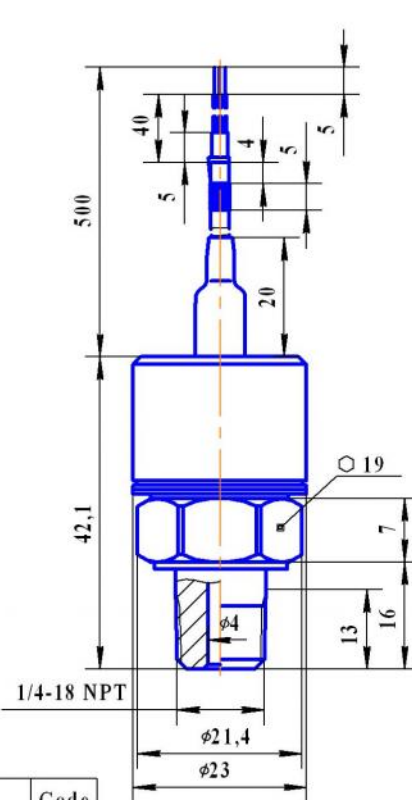

Drawing 3

Thread	Code
1/4-18 NPT	K

(in accord with
DIN 3866)

7.1 Thread design

HP-P 0,06(0,1...100)-...-M(G)

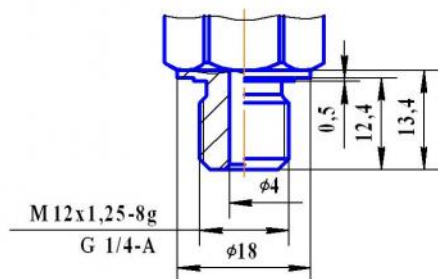

Thread	Code
M 12x1,25-8g	M
G 1/4-A	G

HP-P 0,06(0,1...150)-...-MA(GA)

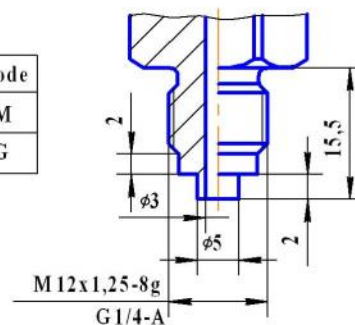

Thread	Code
M 12x1,25-8g	MA
G 1/4-A	GA

Microtensor

Pressure sensors HP-P Series

8 Circuit diagram

"Closed bridge" diagram

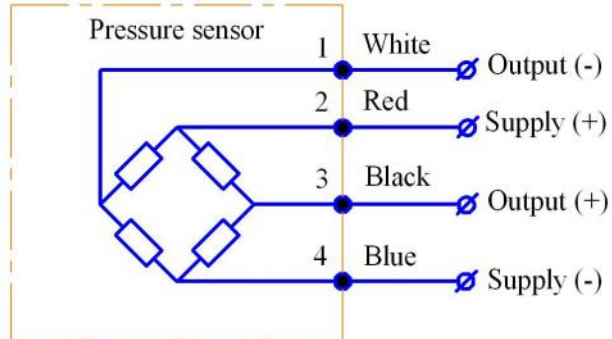

9 Mounting diagrams

HP-P 0,06(0,1...100)-...-M(G)

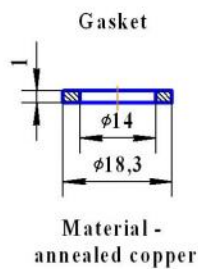
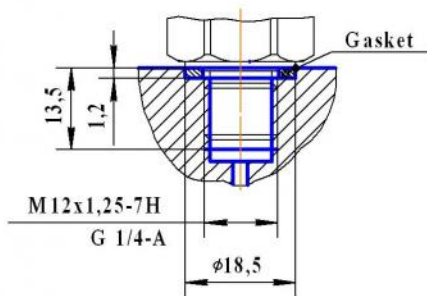

HP-P 0,25(0,4...150)-...-MA(GA)

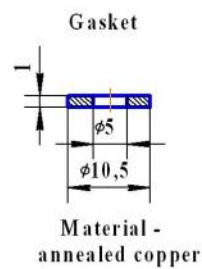
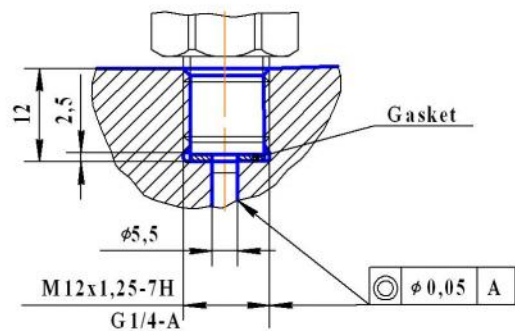

Microtensor

Pressure sensors HP-P Series

10 Type designation

HP-P XXX - XX - X - XX - X

Series

Upper gauge pressure limit

0,06; 0,1; 0,16; 0,25; 0,4; 0,6; 1; 1,6; 2,5; 4;
6; 10; 16; 25; 40; 60; 100; 150 MPa

Operating ambient temperature range

Version 1 - from - 45 to + 125 °C;
Version 3 - from 0 to + 200 °C

Curcuit

0 - “closed bridge” circuit

Power supply type

V - stabilized DC voltage (1-10 V);
C - stabilized DC (0,2-2 mA)

Thread code

K - 1/4-18 NPT
M - M12x1,25-8g;
G - G1/4-A
MA - M12x1,25-8g, end seal;
GA - G1/4-A, end seal

Electrical connection

L - flexible cable 500 mm length

Order example of pressure sensor

Pressure sensor of HP-P series, intended for pressure conversion from 0 to 0,1 MPa, for operation within temperature range from 0 to + 200 °C, with “closed bridge” circuit, DC voltage power supply, M12x1,25-8g thread, end seal and flexible cable 500 mm length:

Pressure sensor HP-P 0,1-30-V-MA-L.

Note: if wished, typical size and cable length (standard 500 mm) can be changed, in this case - in the order should be denoted thread designation and the required length should be added to the cable code L, for example:

Pressure sensor HP-P 0,1-30-V-M12x1-8g-L200.

11 Marking

Marking on the sensor body must contain following information: series, upper gauge pressure limit is in MPa, version of the operating temperature range, circuit type, power supply modification, thread code and order number



Microtensor

Pressure sensors HP-P Series